



# Video over IP Controller



## User Manual

VER 1.0

*[www.infobitav.com](http://www.infobitav.com) [info@infobitav.com](mailto:info@infobitav.com)*

# Thank you for purchasing this product

For optimum performance and safety, please read these instructions carefully before connecting, operating or adjusting this product. Please keep this manual for future reference.

## Surge protection device recommended

This product contains sensitive electrical components that may be damaged by electrical spikes, surges, electric shock, lightning strikes, etc. Use of surge protection systems is highly recommended in order to protect and extend the life of your equipment.

## Table of Contents

1. Introduction.....	1
2. Features.....	1
3. Package Contents.....	1
4. Specifications.....	2
5. Operation Controls and Functions.....	2
5.1 Front Panel.....	2
5.2 Rear Panel.....	3
5.3 IR Pin Definition.....	4
6. Rack Mounting Instruction.....	4
6.1 6U Rack Mounting.....	4
6.2 1U Rack Mounting.....	6
7. Web GUI User Guide.....	7
7.1 Preparation before Entering the System.....	7
7.2 Functions and Operation.....	15
8. Application Example.....	27

## 1. Introduction

This Video over IP Controller is used to control and manage JPEG2000 IP products. It supports dual 100M network ports, which can realize dual-network isolation of Control network and Multicast video distribution network. Built-in Web GUI, TCP and RS-232 control are supported. It supports POE function and wide-band 12V IR signal receiving. Since the demand of IP products is daily increased in the current market, the IP Controller will be widely applied in more and more different scenarios.

## 2. Features

- ☆ Easy to create project, control and manage the system
- ☆ Flexibly support Auto, DHCP and Manual three types of IP configurations
- ☆ HTTPS, SSH, SFTP security compatible
- ☆ Built-in Web GUI control interface, supporting Drag & Drop operations
- ☆ Support image preview
- ☆ Support video, audio, RS-232, IR, KVM control and management of the distributed system
- ☆ Dual network ports (VIDEO LAN port supports POE function) to isolate Controls and Multicast networks.
- ☆ Support LAN/RS-232 port control and third-party central control
- ☆ Support IR signal receiving (3.5mm audio jack, 12V level)
- ☆ 4 channel GPIO control ports (5V/12V optional level)
- ☆ Multiple circuits protection, lightning protection and ESD design
- ☆ Reliable system design, ensuring 7\*24 hours reliable and stable work

## 3. Package Contents

- ① 1 x Video over IP Controller
- ② 1 x 20kHz-60kHz 12V IR Receiver Cable (1.5 meters)
- ③ 1 x 3-pin 3.81mm Phoenix Connector (Male)
- ④ 1 x 6-pin 3.81mm Phoenix Connector (Male)
- ⑤ 2 x Mounting Ears
- ⑥ 4 x Machine Screws (KM3\*6)
- ⑦ 1 x 12V/1A Locking Power Adaptor
- ⑧ 1 x User Manual

## 4. Specifications

Technical	
Network Video Bandwidth	Up to 100M
Transmission Distance	100m CAT 5E/6/6A/7
Control Ports	2 x 100M LAN [RJ45 connector] [VIDEO LAN support POE] 1 x IR IN [3.5mm audio jack, 12V level] 1 x DIGITAL I/O [6-pin 3.81mm phoenix connector] 1 x RS-232 [3-pin 3.81mm phoenix connector]
Dimensions	204mm(W)×98mm(D)×21mm(H)
Housing	Metal Enclosure
Color	Black
Weight	509g
Power Supply	12V/1A
Power Consumption	4.5W
Operating Temperature	0°C ~ 40°C / 32°F ~ 104°F
Storage Temperature	-20°C ~ 60°C / -4°F ~ 140°F
Relative Humidity	20~90% RH (non-condensing)

## 5. Operation Controls and Functions

### 5.1 Front Panel

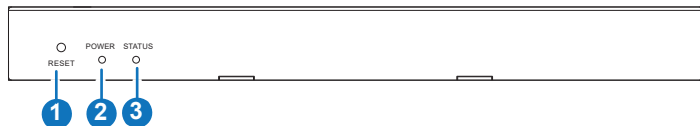

No.	Name	Function Description
1	RESET Button	Press and hold this button (about 10 seconds) until Status LED starts flashing, Controller will be reset automatically.
2	POWER LED	The red LED will light on when the Controller is powered on.
3	STATUS LED	The status LED will flash in yellowish-green every 1 second until Controller boots up completely and Control LAN is ready, then it becomes solid.

## 5.2 Rear Panel

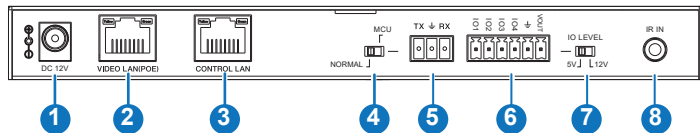

No.	Name	Function Description
1	DC 12V	DC 12V/1A power input port.
2	VIDEO LAN (POE)	100M Video LAN port, supporting POE function. <i>Note: When POE is enabled, DC 12V/1A power supply is not required.</i>
3	CONTROL LAN	The TCP/IP control network port.
4	MCU/Normal DIP Switch	<b>Normal mode:</b> The RS-232 port is used for serial port commands control. <b>MCU mode:</b> The RS-232 port is used for MCU software upgrade.
5	3-pin Phoenix Connector	RS-232 serial communication port.
6	6-pin Phoenix Connector	4 channel I/O level outputs, 1 channel grounding, 1 channel power supply to the outside.
7	IO LEVEL DIP Switch	Used to control I/O level output and VOUT voltage. Switch to left: 5V I/O level output, VOUT is 5V. Switch to right: 12V I/O level output, VOUT is 12V.
8	IR IN	12V IR signal input port.

## 5.3 IR Pin Definition



IR RECEIVER

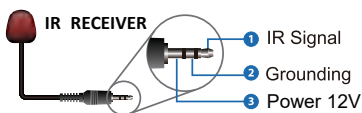

## 6. Rack Mounting Instruction

### 6.1 6U Rack Mounting

This Controller can be mounted in a standard 6U rack (Please contact your supplier for 6U rack sale). The mounting steps are as follows:

**Step 1:** Use included screws to fix two mounting ears on the Controller, as shown in the figure below:

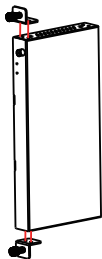

**Step 2:** Insert the Controller with mounting ears into a 6U rack (up to 10 units can be installed vertically), as shown in the figure below:

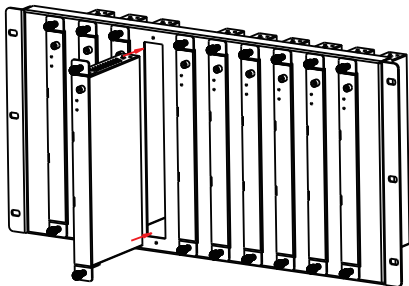

**Step 3:** Use screws to fix mounting ears on the rack to complete the mounting, as shown in the figure below:

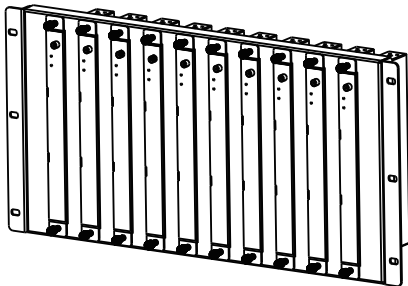

## 6.2 1U Rack Mounting

This Controller also can be mounted in a standard 1U rack (up to 4 units can be installed horizontally). The mounting steps are as follows:

**Step 1:** Stack two Controllers on top of each other, then use included screws to fix two 1U rack panels on the Controllers, as shown in the figure below:

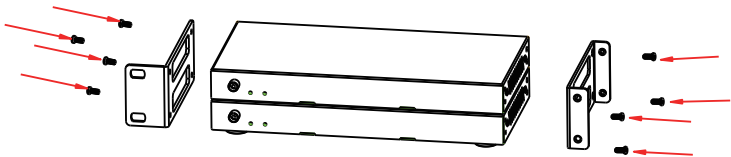

**Step 2:** Fix two 1U rack panels on another two stacked Controllers in the same way, then use screws to fix two 1U rack panels together, as shown in the figure below:

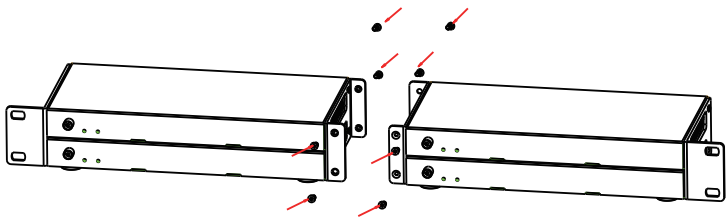

**Step 3:** Fasten screws between two 1U rack panels, so that four Controllers are mounted in a 1U rack, as shown in the figure below:

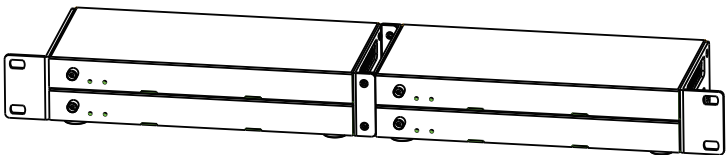



## 7. Web GUI User Guide

### 7.1 Preparation before Entering the System

You can use Controller's Web GUI to control all IP products at the Switch. The operation method is shown as below:

**Step 1:** Input the Controller's default IP address (192.168.0.225) or the URL (http://controller.local) into the Web browser address bar on the PC to enter the Web GUI login interface.

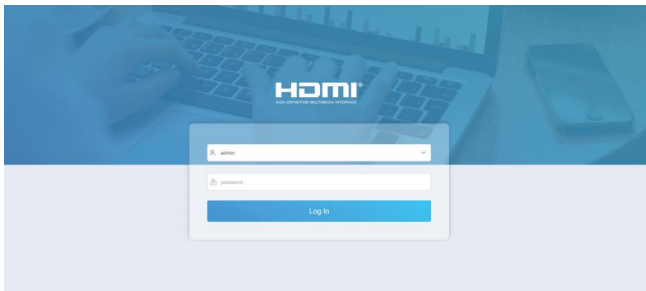

Select the initial username (admin) and input the initial password (1234) on the above login interface. Then, click “Log In” to enter the Web GUI interface. For the first time, you need to setup the project, as shown in the following figure:

Welcome to AV over IP system setup guide. It leads you to create the system easily by following steps.

You can click the [Close] button to load an existing project in web page directly.

Close

Next

**Step 2:** Click the “Close” button to load an existing project in web page directly, or click “Next” button to go to the next step.

To setup AV over IP system, you need to set the IP management mode of the Video LAN domain. The IP management modes are:

- **Automatically managed by Controller Box.**  
This is the mode as factory default. The IP address assignments to Controller Box Video LAN, Encoders and Decoders will be managed by Controller Box firmware automatically. In this mode, there is no need to add router in the system on Video LAN domain.
- **DHCP mode.**  
This is the mode for system in which there is a DHCP router on Video LAN domain to assign IP addresses for Controller Box Video LAN, Encoders and Decoders. The router acts as a DHCP server. It's recommended to set the net mask of router to 255.255.0.0.
- **Static IP mode by manual settings.**  
This is the mode for system in case IP address resources can be assigned manually for Controller Box Video LAN, Encoders and Decoders. Reminders as below:
  - a. The network settings of Controller Box Video LAN, Encoders and Decoders must be on the same subnet.
  - b. It's recommended to set the net mask of Controller Box Video LAN, Encoders and Decoders to 255.255.0.0.

[Back](#) [Next](#)

On this interface, you need to set the IP mode of Video LAN.

### Mode 1: Automatically managed by Controller Box.

Please connect all the devices according to the following diagram.

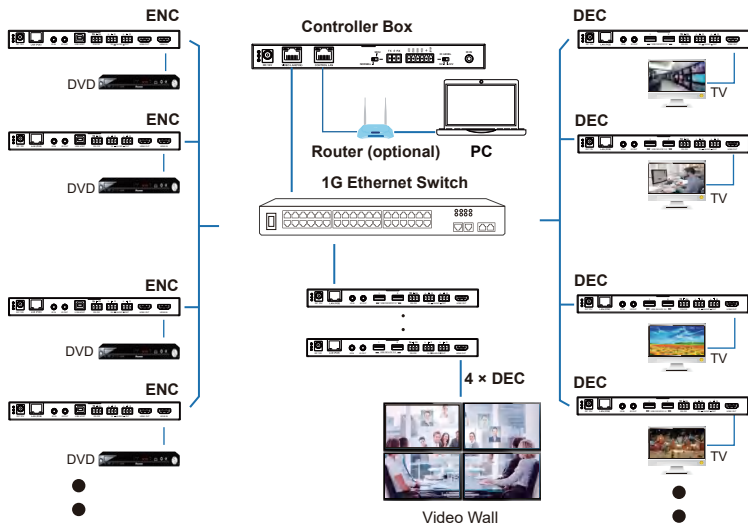

Click the “Next” button and wait for the completion to enter the interface as shown in the figure below.

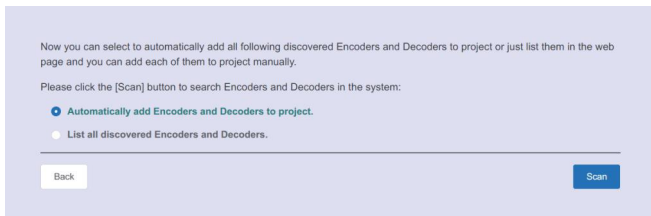

If you select “Automatically add Encoders and Decoders to project”, and click the “Scan” button to enter the Project page. All the connected devices will be listed in the Current Devices list.

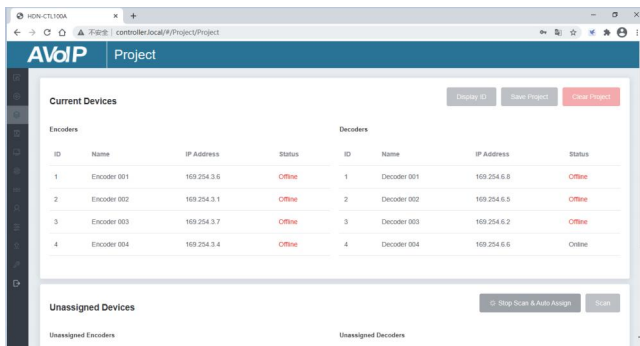

Then click “Stop Scan & Auto Assign” to stop search.

If you select “List all discovered Encoders and Decoders”, and click the “Scan” button to enter the Project page. All the connected devices will be listed in the Unassigned Devices list.

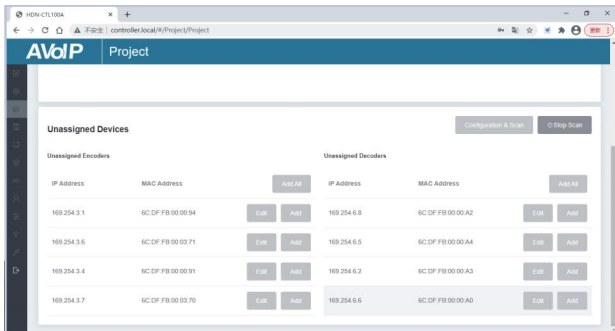

Click “Stop Scan” to stop search. Then the “Add All” buttons and “Add” buttons behind Unassigned Encoders and Unassigned Decoders in the figure below will become operable.

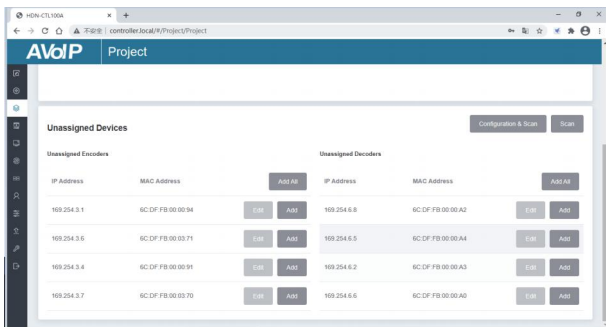

At this time, you can click the “Add” button behind each unregistered Encoder or Decoder to add the device to the project one by one, or click the “Add All” button to add all Encoders or Decoders to the project.

Encoders and Decoders that have been added to the project will appear in the Current Devices list, as shown in the figure below.

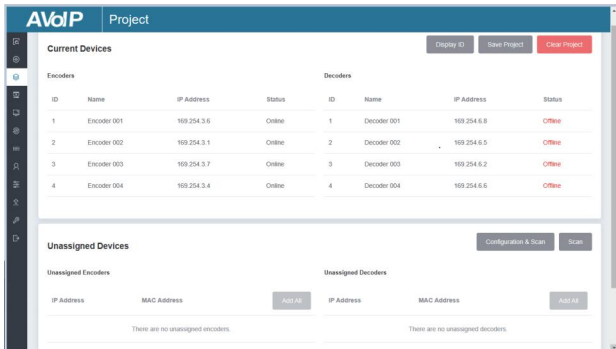

## Mode 2: DHCP mode.

Please connect all the devices according to the following diagram.

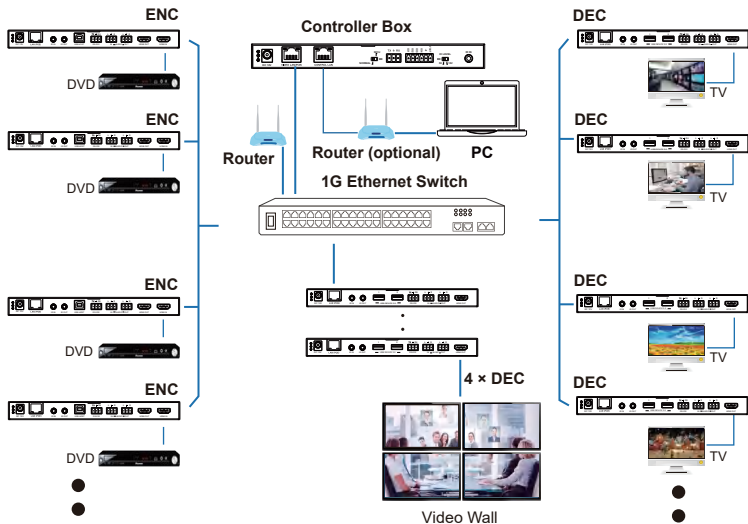

Select “DHCP Mode” on the interface shown below, and click “Next”.

To setup AV over IP system, you need to set the IP management mode of the Video LAN domain. The IP management modes are:

- Automatically managed by Controller Box.  
This is the mode as factory default. The IP address assignments to Controller Box Video LAN, Encoders and Decoders will be managed by Controller Box firmware automatically. In this mode, there is no need to add router in the system on Video LAN domain.
- DHCP mode.**  
This is the mode for system in which there is a DHCP router on Video LAN domain to assign IP addresses for Controller Box Video LAN, Encoders and Decoders. The router acts as a DHCP server. It's recommended to set the net mask of router to 255.255.0.0.
- Static IP mode by manual settings.  
This is the mode for system in case IP address resources can be assigned manually for Controller Box Video LAN, Encoders and Decoders. Reminders as below:
  - The network settings of Controller Box Video LAN, Encoders and Decoders must be on the same subnet.
  - It's recommended to set the net mask of Controller Box Video LAN, Encoders and Decoders to 255.255.0.0.

Back Next

The rest of the steps are the same as the Mode 1 operation.

### Mode 3: Static IP mode by manual settings.

Please connect all the devices according to the following diagram.

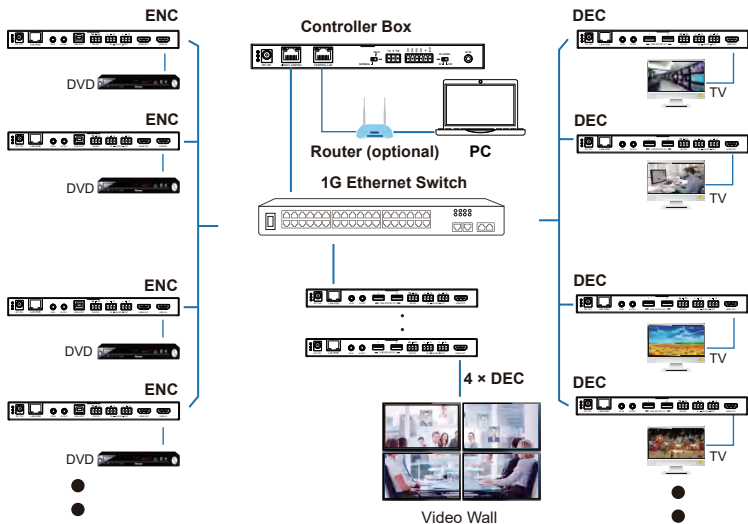

Select “Static IP mode by manual settings” on the interface shown below, and click “Next”.

To setup AV over IP system, you need to set the IP management mode of the Video LAN domain. The IP management modes are:

- Automatically managed by Controller Box.  
This is the mode as factory default. The IP address assignments to Controller Box Video LAN, Encoders and Decoders will be managed by Controller Box firmware automatically. In this mode, there is no need to add router in the system on Video LAN domain.
- DHCP mode.  
This is the mode for system in which there is a DHCP router on Video LAN domain to assign IP addresses for Controller Box Video LAN, Encoders and Decoders. The router acts as a DHCP server. It's recommended to set the net mask of router to 255.255.0.0.
- Static IP mode by manual settings.  
This is the mode for system in case IP address resources can be assigned manually for Controller Box Video LAN, Encoders and Decoders. Reminders as below:
  - The network settings of Controller Box Video LAN, Encoders and Decoders must be on the same subnet.
  - It's recommended to set the net mask of Controller Box Video LAN, Encoders and Decoders to 255.255.0.0.

After entering the interface shown in the figure below, manually set the IP address, subnet mask and gateway of the Video LAN.

Controller Box Video LAN port Network Settings:

IP Address

Subnet Mask

Gateway

Reminder:

Once Controller Box Video LAN network is set, the IP addresses of following discovered Encoders and Decoders will be assigned to the same domain with Controller Box Video LAN. Please click the [Next] button to set the IP address range of Encoders and Decoders.

**Note:**

*It's strongly recommended to use different IP network domain from Control LAN port.*

After the progress reaches 100%, enter the interface as shown in the figure below.

**Encoders and Decoders IP Addresses Range Settings:**

Encoders IP Address From  To

Decoders IP Address From  To

Reminder:

To easily manage the IP addresses of Encoders and Decoders, it's strongly recommended that you can set the IP addresses of Encoders and Decoders to different segments correspondingly. For example:

Encoders IP address from 169.254.3.1 to 169.254.3.254

Decoders IP address from 169.254.6.1 to 169.254.6.254

---

On this interface, you can set the IP address range of Encoders and Decoders. After the setting is complete, click the “Next” button to enter the interface as shown in the figure below.

Now you can select to automatically add all following discovered Encoders and Decoders to project or just list them in the web page and you can add each of them to project manually.

Please click the [Scan] button to search Encoders and Decoders in the system:

Automatically add Encoders and Decoders to project.

List all discovered Encoders and Decoders.

---

The rest of the steps are the same as the Mode 1 operation.



## 7.2 Functions and Operation

### ■ Preview Page

On this page, you can preview the Encoder/Decoder by clicking the drop-down list on the right side.

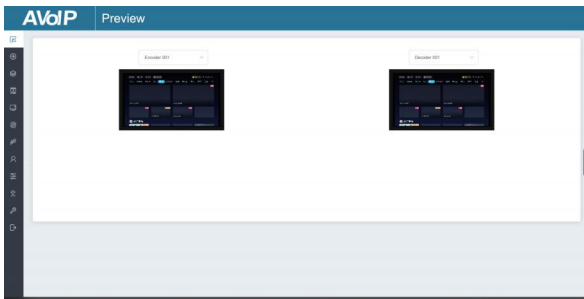

### ■ Matrix Control Page

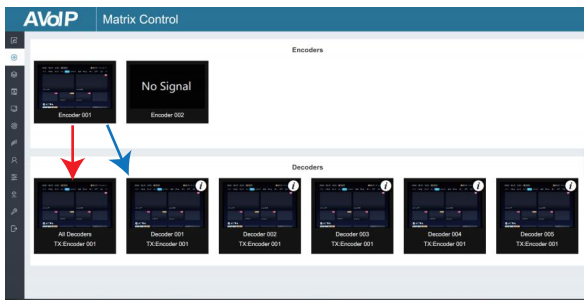

① **Encoders:** Display all the current Encoders. The text in the figure is the name of the device.

② **Decoders:** Display all the current Decoders. The text on the first line is the name of the Decoder, and the text on the second line refers to the Encoder where the signal resource is from.

## Operating Instructions:

- (1) If an Encoder shows “No Signal”, it means that the Encoder cannot be dragged.
- (2) If there is an image on an Encoder, it means that the Encoder can be dragged. As shown in the figure above, if an Encoder is dragged to the place where the red arrow points to, all Decoders will share the same signal resource from this Encoder; if an Encoder is dragged to the place where the blue arrow points to, only the indicated Decoder can receive signals from this Encoder.

## ■ Project Page

The screenshot shows the AVoIP Project Page interface. At the top, there is a blue header with the AVoIP logo and the word "Project". Below the header, there are three buttons: "Display ID", "Save Project", and "Clear Project". The main content area is divided into two sections: "Current Devices" and "Unassigned Devices".

**Current Devices**

Encoders				Decoders			
ID	Name	IP Address	Status	ID	Name	IP Address	Status
1	Encoder 001	193.254.3.1	Online	1	Decoder 001	193.254.6.25	Online
2	Encoder 002	193.254.3.2	Online	2	Decoder 002	193.254.6.25	Online
				3	Decoder 003	193.254.6.30	Online
				4	Decoder 004	193.254.6.15	Online
				5	Decoder 005	193.254.6.20	Online

**Unassigned Devices**

Configuration & Scan    Scan

Unassigned Encoders    Unassigned Decoders

IP Address    MAC Address    Scan    IP Address    MAC Address    Scan

- ① **Current Devices:** Devices that have been added to the current project.
- ② **Unassigned Devices:** Devices not added to the current project.

## Operating Instructions:

- (1) Click “Display ID” to display the ID or PATTERN of the Decoders.
- (2) Click “Save Project” to save the project file (config\_file.json), so that you can use the saved project next time without scanning devices again.
- (3) Click “Clear Project” to clear the current project, then you will need to setup devices again.
- (4) Click “Scan” to search devices that do not appear in the current project; Click “Stop Scan”, then it will stop searching.

- (5) Click “Configuration & Scan” to search new devices automatically and add to the current project.

## ■ Encoders Page

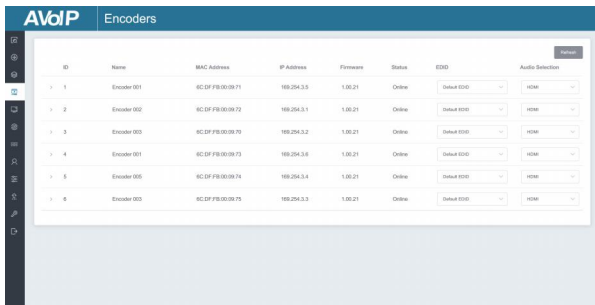

The screenshot shows the 'Encoders' page in the AvVoIP interface. It features a table with columns for ID, Name, MAC Address, IP Address, Firmware, Status, EDID, and Audio Selection. There are six rows of data, each with a refresh icon to the left of the ID. A 'Refresh' button is located in the top right corner of the table area.

ID	Name	MAC Address	IP Address	Firmware	Status	EDID	Audio Selection
1	Encoder 001	8C:DF:F8:00:09:71	192.254.3.5	1.00.21	Online	Default EDID	HDMI
2	Encoder 002	8C:DF:F8:00:09:72	192.254.3.1	1.00.21	Online	Default EDID	HDMI
3	Encoder 003	8C:DF:F8:00:09:70	192.254.3.2	1.00.21	Online	Default EDID	HDMI
4	Encoder 001	8C:DF:F8:00:09:73	192.254.3.6	1.00.21	Online	Default EDID	HDMI
5	Encoder 005	8C:DF:F8:00:09:74	192.254.3.4	1.00.21	Online	Default EDID	HDMI
6	Encoder 003	8C:DF:F8:00:09:75	192.254.3.3	1.00.21	Online	Default EDID	HDMI

- ① **ID:** The ID of the current device. (Note: ID is not duplicated.)
- ② **Name:** The name of the current device. (Note: Name is not duplicated.)
- ③ **MAC Address:** The MAC Address of the current device.
- ④ **IP Address:** The IP Address of the current device.
- ⑤ **Firmware:** The Firmware version No. of the current device.
- ⑥ **Status:** The status (online or offline) of the current device.
- ⑦ **EDID:** The EDID of the current device.
- ⑧ **Audio Selection:** The Audio Selection of the current device.

### Operating Instructions:

- (1) Click “Refresh” to refresh the data of the current Encoders.
- (2) Click the drop-down list of EDID to set the current Encoder’s EDID.
- (3) Click the drop-down list of Audio Selection to set the current Encoder’s audio output.
- (4) Click the icon on the left of ID to check the detail information about the current Encoder, as shown in below:

**AVoIP** Encoders

ID	Name	MAC Address	IP Address	Firmware	Status	EDD	Audio Selection
1	Encoder 001	8C:DF:F8:00:08:71	109.254.3.5	1.09.21	Online	Default EDD	HDM

Name: Encoder 001

Update ID: Select

CEC Pass-through: On

Power LED Flashing: Off

Copy EDD: Select a decoder

Serial Settings: [Apply](#)

Network Settings: [Apply](#)

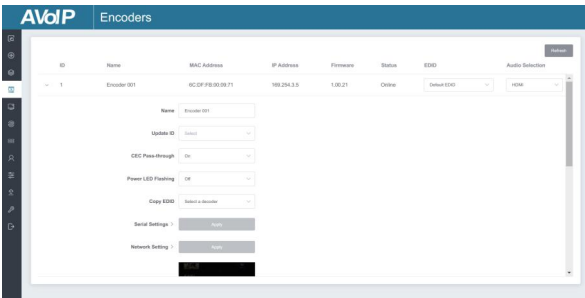

**AVoIP** Encoders

ID	Name	MAC Address	IP Address	Firmware	Status	EDD	Audio Selection
2	Encoder 002	8C:DF:F8:00:08:72	109.254.3.1	1.09.21	Online	Default EDD	HDM

Network Setting: [Apply](#)

Preview: 

Reboot: [Reboot](#)

Replace (Must be offline): [Replace \(Must be offline\)](#)

Remove from Project: [Remove from Project](#)

Factory Default Reset: [Factory Default Reset](#)

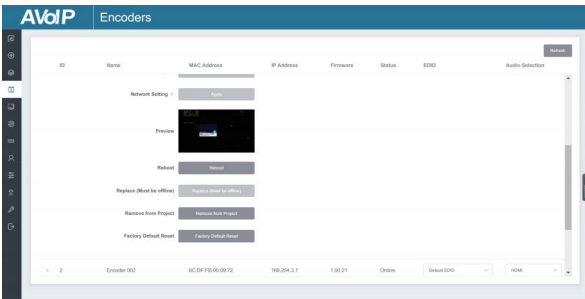

On this page, you can setup the current Encoder as required.

## Decoders Page

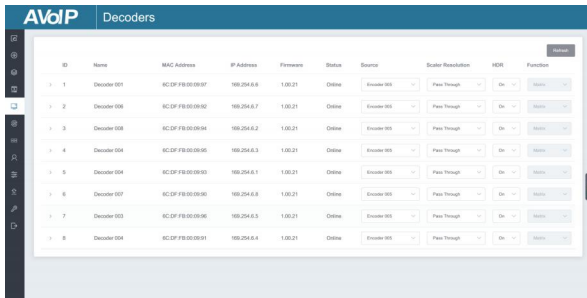

ID	Name	MAC Address	IP Address	Firmware	Status	Source	Scaler Resolution	HDR	Function
1	Decoder 001	8C:DF:FB:00:08:07	192.254.6.6	1.00.21	Online	Encoder 001	Pass Through	On	Matrix
2	Decoder 008	8C:DF:FB:00:08:02	192.254.6.7	1.00.21	Online	Encoder 001	Pass Through	On	Matrix
3	Decoder 008	8C:DF:FB:00:08:04	192.254.6.2	1.00.21	Online	Encoder 001	Pass Through	On	Matrix
4	Decoder 004	8C:DF:FB:00:08:05	192.254.6.3	1.00.21	Online	Encoder 001	Pass Through	On	Matrix
5	Decoder 004	8C:DF:FB:00:08:03	192.254.6.1	1.00.21	Online	Encoder 001	Pass Through	On	Matrix
6	Decoder 007	8C:DF:FB:00:08:06	192.254.6.8	1.00.21	Online	Encoder 001	Pass Through	On	Matrix
7	Decoder 003	8C:DF:FB:00:08:06	192.254.6.5	1.00.21	Online	Encoder 001	Pass Through	On	Matrix
8	Decoder 004	8C:DF:FB:00:08:01	192.254.6.4	1.00.21	Online	Encoder 001	Pass Through	On	Matrix

- ① **ID:** The ID of the current device. (Note: ID is not duplicated.)
- ② **Name:** The name of the current device. (Note: Name is not duplicated.)
- ③ **MAC Address:** The MAC Address of the current device.
- ④ **IP Address:** The IP Address of the current device.
- ⑤ **Firmware:** The Firmware version No. of the current device.
- ⑥ **Status:** The status (online or offline) of the current device.
- ⑦ **Source:** The signal source (Encoder) of the current device.
- ⑧ **Scaler Resolution:** The resolution of the current device.
- ⑨ **HDR:** The HDR status of the current device.
- ⑩ **Function:** The mode of the current device.

### Operating Instructions:

- (1) Click “Refresh” to refresh the data of the current Decoders.
- (2) Click the drop-down list of Source to select the current Decoder’s signal source.
- (3) Click the drop-down list of Scaler Resolution to select the current Decoder’s resolution.
- (4) Click the drop-down list of HDR to turn on/off HDR.
- (5) Click the drop-down list of Function to select the current Decoder’s mode.
- (6) Click the icon on the left of ID to check the detail information about the current Decoder, as shown in below:

**AVoIP** Decoders

ID	Name	MAC Address	IP Address	Firmware	Status	Source	Scaler Resolution	HDR	Function
1	Decoder 001	EC:D7:FB:00:09:87	193.254.6.6	1.00.21	Online	Encoder 006	Pass Through	On	None

Name:   
 Update ID:   
 CRC Pass-Through:   
 Power LED Flashing:   
 Display Product ID:   
 Serial Settings:   
 Network Setting:

**AVoIP** Decoders

ID	Name	MAC Address	IP Address	Firmware	Status	Source	Scaler Resolution	HDR	Function
2	Decoder 006	EC:D7:FB:00:09:92	193.254.6.7	1.00.21	Online	Encoder 005	Pass Through	On	None

Network Setting:   
 Preview:   
 Refresh:   
 Replace (Must be offline):   
 Remove from Project:   
 Factory Default Reset:

On this page, you can setup the current Decoder as required.

## ■ Locked Signal Routing Page

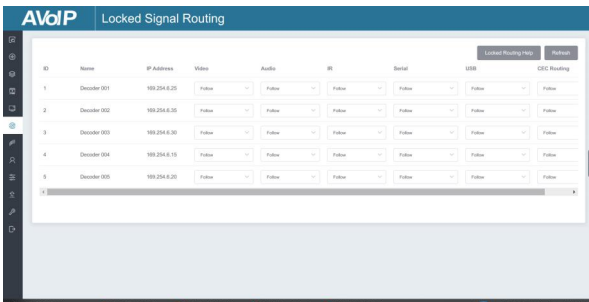

On this page, you can independently route the different signals between Encoder & Decoder devices. Please click “Locked Routing Help” for details.

## ■ Video Wall Management Page

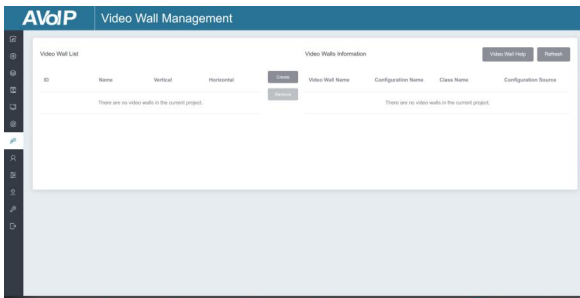

On this page, you can create and configure video wall as required. Please follow below steps to create a video wall.

**Step 1:** Click “Create”, a pop-up window will be shown as below:

## Create a new Video Wall



Video Wall ID: 1

Name: Video Wall 1

Horizontal: 3

Vertical: 3

Create

You can set the Video Wall ID, Name, Horizontal and Vertical panel numbers. Then click “Create” to create the Video Wall.

*Note: Up to 9 video walls can be created.*

**Step 2:** Select the video wall that you want to configure on the “Video Wall List”, then click “Assign Decoder” to enter the Decoder assignment page. Click each screen to select the corresponding Decoder device, then click “Apply”.

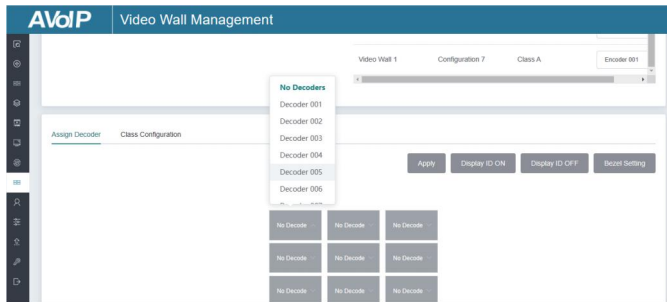

*Note: A Decoder can only be assigned to one video wall.*



**Step 3:** Click “Class Configuration” to enter the class configuration page, then click each screen to select the corresponding Class as required (the same class name will form a video wall, you can create a regular or irregular video wall by Class Configuration). Then click “Apply”.

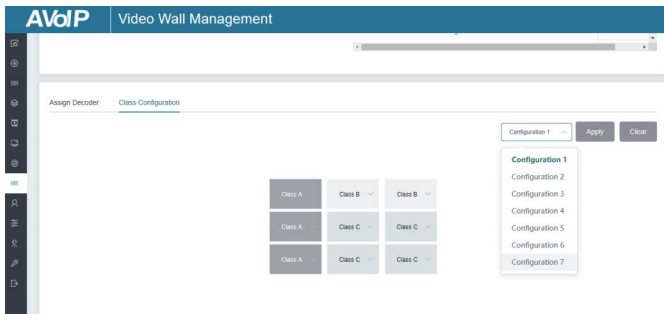

*Note: Up to seven configurations can be set up for different application scenarios.*

**Step 4:** After configuration, you can switch to “Video Wall Control” page for video preview, as shown in below.

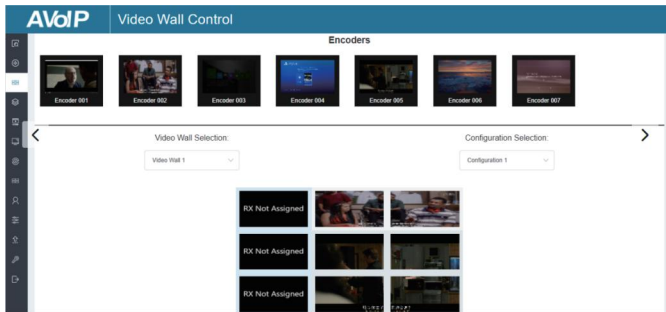

On this page, you can select different video walls and configurations that you have set up by clicking the drop-down box on the right of “Video Wall Selection / Configuration Selection”. Besides, you can directly drag Encoders at the top of the page to the video wall to change signal sources.

If you want to delete a video wall, just select the video wall on the “Video Wall List”, then click “Remove”. A prompt window will pop up and you can delete it after clicking “Yes”.

Remove Video Wall 1

×

Are you sure you want to remove Video Wall 1 from the current project?

No

Yes

The screenshot shows the AVoIP Video Wall Manager interface. At the top, there is a blue header with the AVoIP logo and the text "Video Wall Manager". A green notification banner states "The video wall has been removed from the project!". Below the header, there are two main sections: "Video Wall List" and "Video Walls Information". The "Video Wall List" section contains a table with columns for ID, Name, Vertical, and Horizontal, and a "Remove" button. The "Video Walls Information" section contains a table with columns for Video Wall Name, Configuration Name, Class Name, and Configuration Sour, and a "Refresh" button. Both tables currently display "There are no video walls in the current project." A vertical sidebar on the left contains various navigation icons.

#### Notes:

- (1) Each Decoder can be set into a part of a video wall array. Each system can contain multiple video walls with different sizes. Each video wall can be assigned to different screens and different layouts that range from 1x2 up to 9x9.
- (2) The controller creates and manages the video wall configurations and provides a simplified control interface and API commands to third party control system.

## ■ Users Page

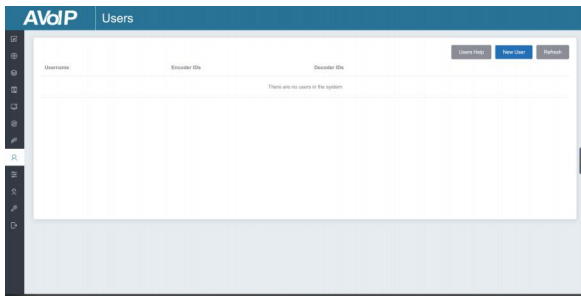

On this page, you can add new user accounts.

## ■ Controller Settings Page

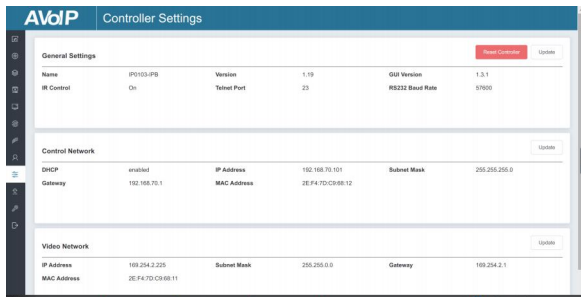

- ① **General Settings:** The basic settings of the Controller.
- ② **Control Network:** The network port configuration of the Controller connected to the Switch.
- ③ **Video Network:** The network port configuration of the Controller connected to video source devices.

You can update the settings or reset the Controller.

## ■ Firmware Update Page

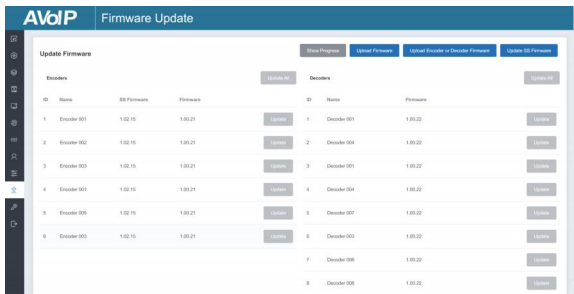

On this page, you can separately update the firmware of any Encoder/Decoder by clicking the corresponding “Update” button on the right, or update all the firmwares of Encoder/Decoder simultaneously by clicking the corresponding “Update All” button. Also you can update the Second Stream chip firmware by clicking the “Update SS Firmware” button.

## ■ Password Update Page

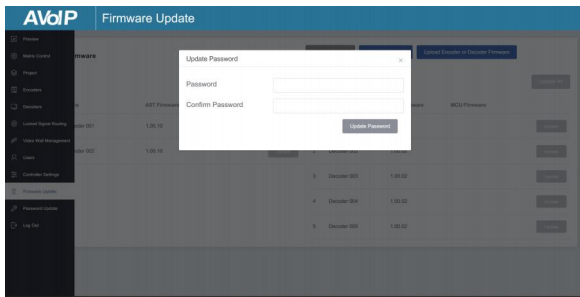

On this page, you can change the password. Note that after changing, it will skip to the Web browser home page or the Web GUI login interface automatically. You need to log in the Web GUI again with the new password.

## ■ Log Out Page

Click “Log Out” on the left, the Web GUI will exit and skip to the login interface automatically.

## 8. Application Example

### Mode 1: Automatically managed by Controller Box.

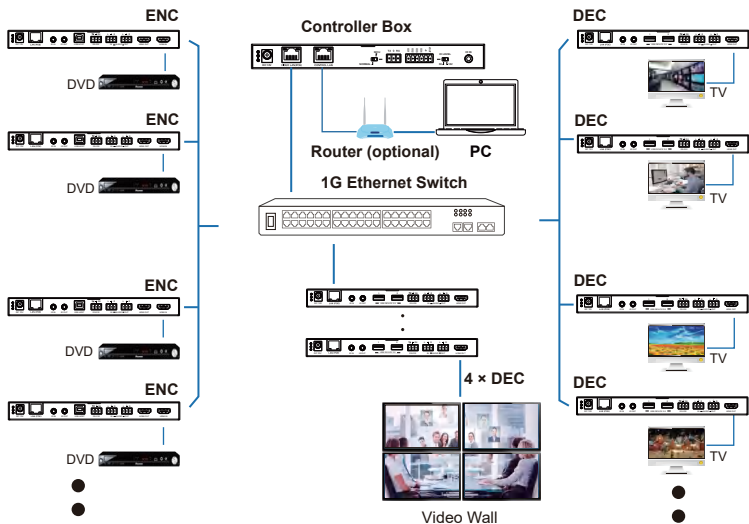

## Mode 2: DHCP mode.

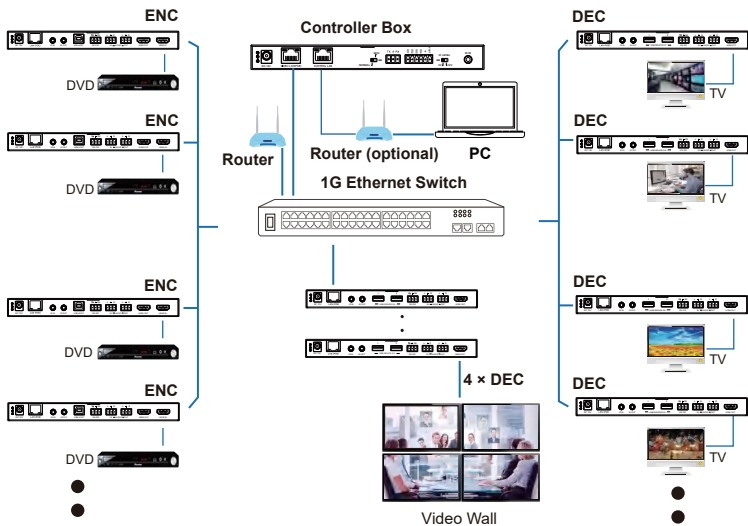

### Mode 3: Static IP mode by manual settings.

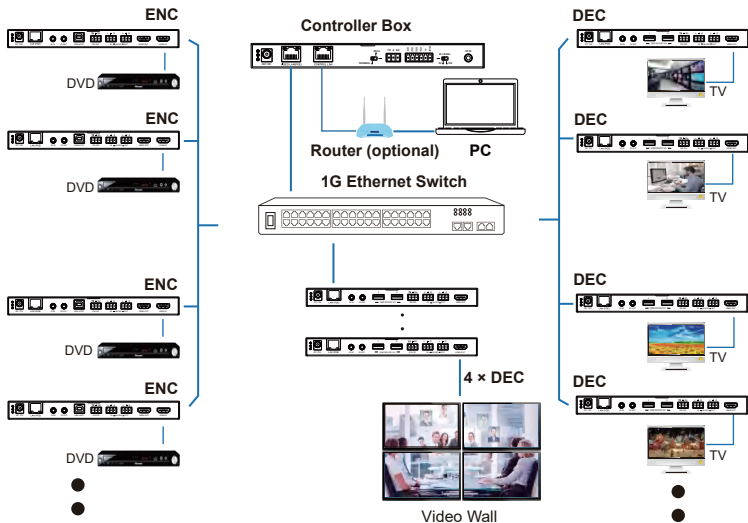

#### Notes:

- (1) For the default IP mode of Control LAN port of the Controller Box is DHCP, the PC also needs to be set to "Obtain an IP address automatically" mode, and an optional DHCP server (e.g. network router) is recommended in the system.
- (2) If there is no DHCP server in the system, 192.168.0.225 will be used as the IP address of Control LAN port. You need to set the IP address of the PC to be in the same network segment. For example, set PC's IP address as 192.168.0.88.
- (3) You can access the Web GUI by inputting URL "<http://controller.local>" or the Control LAN port IP address 192.168.0.225 (in case of no optional Router) on your computer's browser.
- (4) No need to care about settings of Video LAN port of the Controller Box in Mode 1 and Mode 2, as they are managed by Controller automatically.
- (5) When the Network Switch does not support PoE, the Encoder, Decoder and Controller Box should be powered by DC power adapter.