

User Manual

iMIX 63 Stereo mixing preamplifier



Safety instructions

When using this electronic device, basic precautions should always be taken, including the following:

- 1 Read all instructions before using the product.
- 2 Do not use this product near water (e.g., near a bathtub, washbowl, kitchen sink, in a wet basement or near a swimming pool etc).
- 3 Use this device when you are sure that preamplifier has a stable base and it is fixed securely.
- 4 This product, in combination with loudspeakers and amplifiers may be capable of producing sound levels that could cause permanent hearing loss. Do not operate for a long period of time at a high volume level or at a level that is uncomfortable. If you experience any hearing loss or ringing in the ears, you should consult with otorhinolaryngologists.
- 5 The product should be located away from heat sources such as radiators, heat vents, or other devices that produce heat.
- 6 The product should be connected to a power supply that is described in the operating instructions or are marked on the product.
- 7 The power supply should be undamaged and never share an outlet or extension cord with other devices. Never leave device plugged into the outlet when it is not being used for a long period of time.
- 8 Care should be taken that objects do not fall into liquids and liquids would not be spilled on the device.
- 9 The product should be serviced by qualified service personnel if:
 - The power supply or the plug has been damaged.
 - Objects have fallen into or liquid has been spilled on the product.
 - The product has been exposed to rain.
 - The product has been dropped or the enclosure damaged.
- 10 There are some areas with high voltage inside, to reduce the risk of electric shock do not remove cover of the microphone receiver or power supply. The cover should be removed by the qualified personnel only.

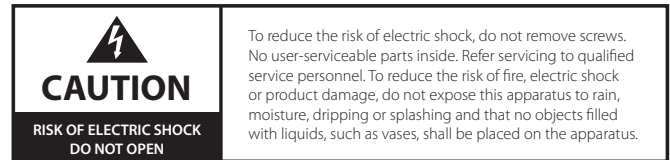

Table of contents

Before you start

Introduction.....	2
Features.....	2

Operation

Front panel.....	3
Rear panel.....	4
Front panel operation.....	5
Rear panel operation.....	6

Controls and connectors

Connectors.....	7
Cable wiring examples.....	7-8
Application example.....	9-10

Specifications

Block diagram.....	11
General specifications.....	12

Before you start

iMIX 63 is a professional mixer preamplifier, with built-in six balanced combo and three stereo RCA audio inputs. Input gain selector for the balanced combo inputs, phantom power, signal and output level indication, balanced stereo output and 24V power supply are collected in to this device, to make iMIX 63 more flexible and easy adapted to various of installations. Please read this manual carefully to get the most important information.

FEATURES

- Six combo XLR inputs with selectable gain, Line or Mic. Three stereo RCA inputs
- Phantom power. Switchable on each combo inputs separately
- Priority input
- DC 24V input connector for external power supply
Signal and four LED bar for signal level indication in the output
- 3 band equalizer. Low, mid and high.

Operation

Front Panel

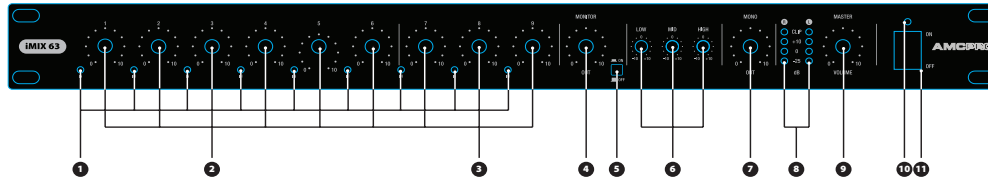

- 1. Indication | 2. Volume combo XLR | 3. Volume stereo RCA | 4. Monitor | 5. Monitor ON/OFF button | 6. Equalizer | 7. Mono
- 8. LED bar indicator | 9. Master | 10. Power ON indicator | 11. Power button

Operation

Rear Panel

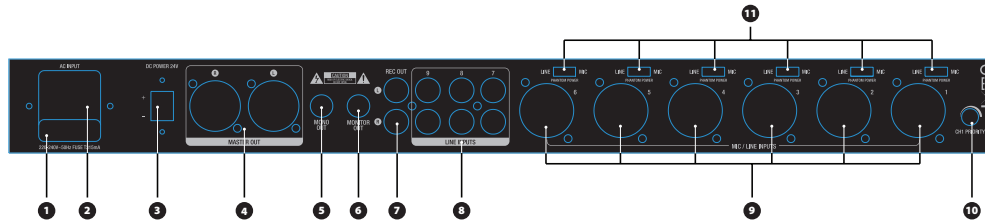

1. Fuse holder | 2. Main power connector | 3. DC 24V conector | 4. Master out | 5. Mono output
 6. Monitor output | 7. REC output | 8. Line inputs | 9. MIC/LINE combo inputs | 10. Priority control | 11. Input gain selector

Operation

Front panel operation

INDICATION

These green LEDs indicate audio signal in the input.

VOLUME COMBO XLR

These rotary knobs are for adjusting volume level of the universal mono inputs. First six inputs can be used as balanced line level as well as microphone level inputs. The phantom power can be activated for these inputs separately in rear panel. The input gain selector is located in the rear panel too.

VOLUME STEREO RCA

These rotary knobs are for adjusting volume level of the line level RCA inputs. Input 7, 8 and 9 are line level, unbalanced, stereo inputs.

MONITOR

This is volume control for adjusting audio level in the balanced monitor output. In this output can be linked audio from the combo inputs.

MONITOR ON/OFF BUTTON

If this button is in the "ON" position, all combo inputs are linked in to monitor output. At this moment only input 7, 8 and 9 are available in the master, mono and rec. outputs. When the button is off, all inputs are linked in to main, mono and rec. output, at this moment monitor output is inactive.

EQUALIZER

3 band: low, mid and high equalizer. Center frequency of the "LOW" tones equalizer is 80Hz, adjusting level ± 10 dB. The "MID" tones can be adjusted in ± 10 dB range. Center frequency 2.5kHz. "HI" tones are ready to be adjusted in ± 10 dB range. Center frequency – 12kHz.

MONO

This volume control is designed to adjust volume level in the balanced mono output. If monitor button is "ON", in this output are available audio from stereo RCA inputs only.

LED BAR INDICATOR

This is level indicator of the master output.

MASTER

This potentiometer is designed to adjust audio level in the master output.

"POWER ON" INDICATOR

This LED indicates status. LED indicates if preamplifier is turned on.

POWER BUTTON

Designed to turn on/off main power.

Operation

Rear panel operation

FUSE HOLDER

Use T315mA 250V fuse only. Contact with qualified service if fuse blows up constantly.

MAIN POWER CONNECTOR

The connector is used to connect the AC 220V – 240V ~50Hz power to preamplifier.

DC 24V CONECTOR

This connector is designed to power up preamplifier when the main power is unavailable. Use only 24V power supply or batteries and take attention to polarity during the wiring. If both, AC and DC power are connected; preamplifier will use main AC power.

MASTER OUT

This is balanced, stereo line level output, XLR connectors.

MONO OUTPUT

This is line level, balanced output, 6.3mm TRS connector.

MONITOR OUTPUT

This is line level, balanced output, 6.3mm TRS connector. Signal in this output is available when MONITOR BUTTON is in the ON position. In this output

only signal from combo connectors (input 1 - 6) is available.

REC OUTPUT

This is line level, unbalanced stereo output, RCA connector. Signal in this output is independent from master, mono or monitor knobs. The signal level in this output depends from input volume controls only.

LINE INPUTS

This is line level, unbalanced stereo RCA inputs.

MIC/LINE INPUTS

This is universal, balanced combo inputs for XLR and 6.3mm connectors. Gain of these inputs and phantom power can be set by the switch located near the connectors. These inputs are suitable for microphone and line level audio.

PRIORITY

Input 1 can be set as priority input. To set priority, please turn priority potentiometer to the right until the end. To deactivate priority turn to the left until the end.

GAIN SELECTOR

Gain selector is designed to set the gain of the combo inputs and turn on +20V phantom power. When gain selector switch is set in to the "PHANTOM POWER" position, the input gain is set to microphone automatically.

Controls and connections

Connectors

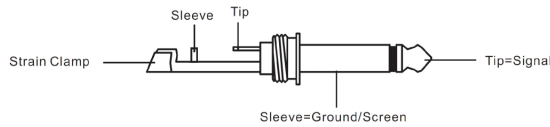

TS connector

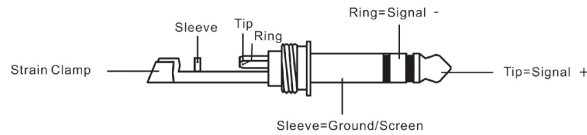

TRS connector



XLR male connector

RCA connector

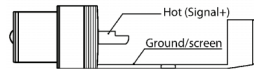

XLR female connector

Cable wiring examples



Cable to balanced input from balanced output. TRS connectors.



Cable to unbalanced input from balanced output. TRS and TS connectors.



Cable to balanced input from unbalanced output. TS and TRS connectors.



Cable to unbalanced input from unbalanced output. TS connectors.

Controls and connections



Cable to balanced input from balanced output. XLR connectors.



Cable to unbalanced input from balanced output. XLR and TS connectors.



Cable to balanced input from unbalanced output. TS and XLR connectors.



Cable to balanced input from balanced output. TRS and XLR connectors.



RCA cable.



Cable to unbalanced input from RCA output. RCA and TS connectors.



Cable to balanced input from RCA output. RCA and XLR connectors.



Cable to balanced input from RCA output. RCA and TRS connectors.



Cable to RCA input from balanced output. RCA and XLR connectors.

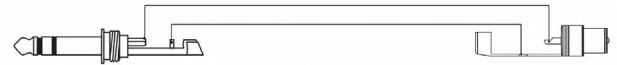

Cable to RCA input from balanced output. RCA and TRS connectors.

Controls and connections

Application example
Conferences room with audio recording:

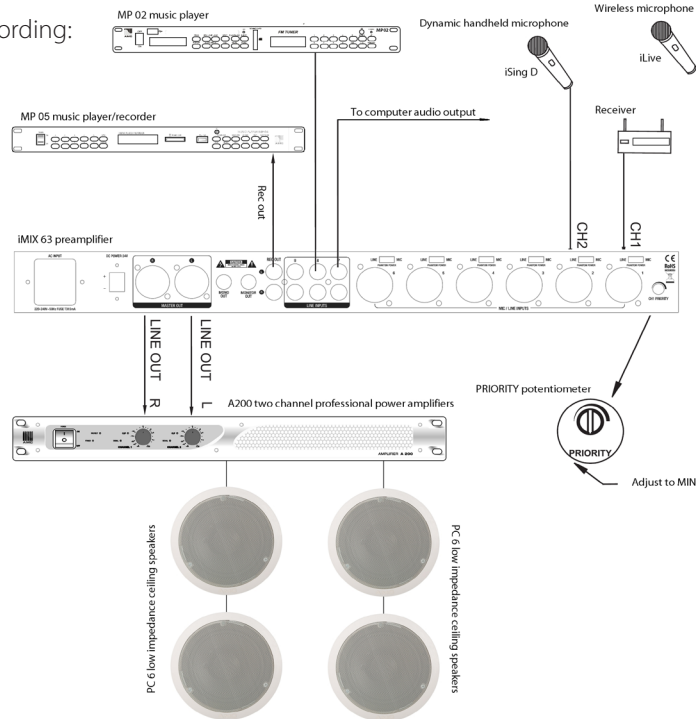

Controls and connections

Background music station with paging microphone priority:

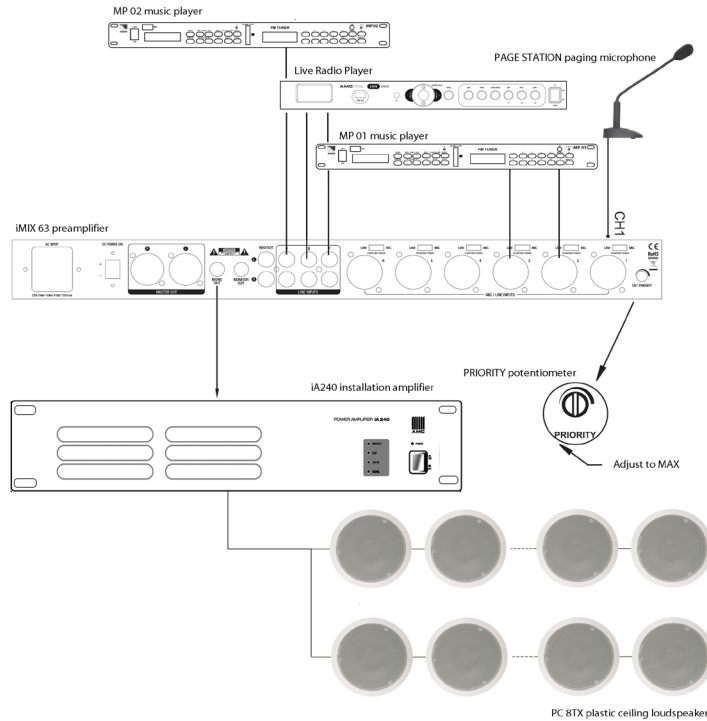

Specifications

Block diagram

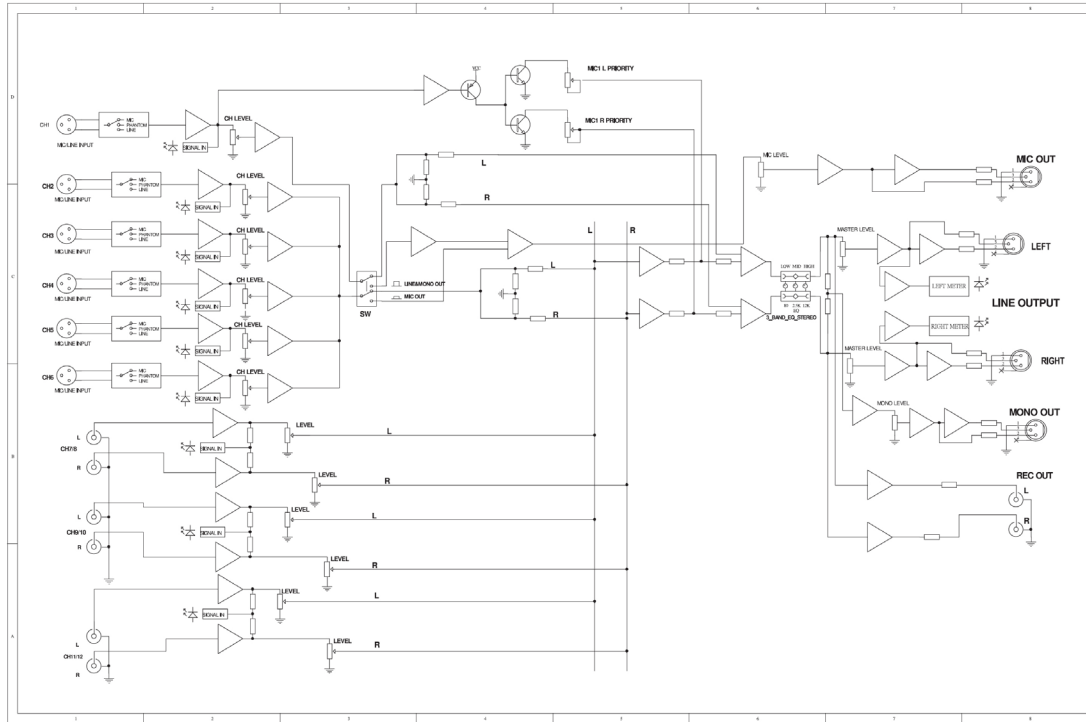

General Specifications

Power supply	AC 230V, 50Hz or 24V DC
DC 24V power consumption	9,6W
AC power consumption	10,5W
Phantom power voltage	18V - 20V
Combo input gain (line level)	-12dBu
Maximum input level	+12dBu
Combo input gain (Mic level)	-52dBu
Maximum input level	-15dBu
RCA input gain	-4dBu
Maximum MAIN output level	+16dBu
Maximum MONO output level	+27dBu
Maximum MONITOR output level	+27dBu
Maximum REC output level	+21dBu
THD	0.03% (@ 1kHz)

SN ratio	>103dBu
Crosstalk (input to output)	-82dBu
Microphone input impedance	1,4k Ω
Line input impedance	10k Ω
Output impedance	120 Ω
Frequency response	20 Hz – 22 kHz
Equalization (low)	± 10 dBu @ 80Hz
Equalization (mid)	± 10 dBu @ 2,5kHz
Equalization (High)	± 10 dBu @ 12kHz
Dimensions	483mm x 195 mm x 44 mm
Weight	2.9 kg

The specifications are correct at the time of printing this manual. For improvement purposes, all specifications for this unit, including design and appearance, are subject to change without prior notice.